

SIM2 Multimedia

SIM2 C3X LUMIS RS-232C Control Specifications

Rev. 1.1 (18 September 2009)



Contents

Contents	2
1 Introduction	3
1.1 Setting up the RS-232C Serial connection	3
1.2 Execution of the command	4
2 Commands	5
2.1 Remote Control Keys Codes	5
2.2 Operation Commands	6
2.3 Status Commands	11
3 Examples	14

Revision History

Rev.	Date	Software Version	Description of Change
1.1	18 September 2009	4.01.22 or higher	Changes in sections: 2.1 , 2.2 (with addition of commands On and Off), 2.3 .
1.0	24 July 2009	4.01.18 or higher	Initial version.

1 Introduction

This document describes how to interface the SIM2 C3X LUMIS projector with a Home Theater control system (or a PC) over a direct serial connection.

1.1 Setting up the RS-232C Serial connection

Follow these steps to configure the control system (or the PC) serial port.

- Switch off the control system (or the PC) and the projector.
- Use a standard straight¹ serial cable with 9 pin female to the control system (or the PC) and 9 pin male to the Projector:

RS-232C Control Port

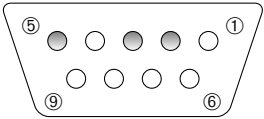
	Pin No	Signal	Definition
 <p>D-SUB 9-pin (female)</p>	1	-	Not used
	2	TD	Transmit data
	3	RD	Receive data
	4	-	Not used
	5	GND	Ground
	6	-	Not used
	7	-	Not used
	8	-	Not used
	9	-	Not used

- Make sure the distances between equipment do not exceed the specifications of the interface (15 m or 50 feet).
- Switch on the control system (or the PC) and, after start up, switch on the projector.
- Set the Serial Port Parameters as shown below:

Communication Parameters

Parameter	Value
Transfer Rate	19200 bps
Data Bits	8
Parity Bit	None
Stop Bit	1
Flow Control	None

- Set the the control system (or the PC program) Communication Mode to Binary (or Hex). ASCII mode is not supported.
- Set the the control system interface (or the PC communication program) Display Mode to Hex.

¹A cable that connects identical pin numbers in each connector: pin ② connects to pin ②, pin ③ to pin ③ and pin ⑤ to pin ⑤.

1.2 Execution of the command

Command execution time may vary from 0.1 to 2.0 seconds, depending on the operation that have been requested.

If the projector is busy when a command is sent, the unit may not accept the command. When several commands are to be sent one after the other, sufficient time between them should be allowed.

When the unit is switched on from Standby wait 15 seconds before sending commands or reading messages sent by the projector.

2 Commands

In this section, serial commands (and respective responses) are listed. Commands (and responses) are series of bytes (numbers holding values from 0 to 255).

In the following, bytes are represented by couples of hexadecimal digits, shown in monospace (fixed-width) type (for example: EF¹). Spaces between bytes (for example: E4_48) have been inserted just to make the command more readable and are not part of the command itself.

Commands do not require any termination character: do not add <LF>, <CR>, <EOT> or the like at the end of the given series of bytes.

2.1 Remote Control Keys Codes

The following serial commands are meant to emulate button presses on the SIM2 C3X LUMIS IR Remote Control. Like remote button presses they interact with the OSD of the projector.

Key	Command
Standby	BE EF 02 06 00 51 E4 48 01 00 00 00 00
0/On/Input	BE EF 02 06 00 6B E6 52 01 00 00 00 00
1	BE EF 02 06 00 80 E5 49 01 00 00 00 00
2	BE EF 02 06 00 B3 E5 4A 01 00 00 00 00
3	BE EF 02 06 00 62 E4 4B 01 00 00 00 00
4	BE EF 02 06 00 D5 E5 4C 01 00 00 00 00
5	BE EF 02 06 00 04 E4 4D 01 00 00 00 00
6	BE EF 02 06 00 37 E4 4E 01 00 00 00 00
7	BE EF 02 06 00 E6 E5 4F 01 00 00 00 00
8	BE EF 02 06 00 89 E7 50 01 00 00 00 00
9	BE EF 02 06 00 58 E6 51 01 00 00 00 00
Select (●)	BE EF 02 06 00 BA E7 53 01 00 00 00 00
Esc	BE EF 02 06 00 0D E6 54 01 00 00 00 00
Arrow Up	BE EF 02 06 00 DC E7 55 01 00 00 00 00
Arrow Left	BE EF 02 06 00 EF E7 56 01 00 00 00 00
Arrow Right	BE EF 02 06 00 3E E6 57 01 00 00 00 00
Arrow Down	BE EF 02 06 00 C1 E6 58 01 00 00 00 00
Menu Left (-)	BE EF 02 06 00 10 E7 59 01 00 00 00 00
Menu Right (+)	BE EF 02 06 00 23 E7 5A 01 00 00 00 00
Freeze	BE EF 02 06 00 F2 E6 5B 01 00 00 00 00
Memory	BE EF 02 06 00 45 E7 5C 01 00 00 00 00
F1	BE EF 02 06 00 94 E6 5D 01 00 00 00 00
F2	BE EF 02 06 00 76 E7 5F 01 00 00 00 00
Info	BE EF 02 06 00 A7 E6 5E 01 00 00 00 00
Auto	BE EF 02 06 00 79 E2 60 01 00 00 00 00
Aspect	BE EF 02 06 00 A8 E3 61 01 00 00 00 00

¹A variety of alternative conventions are used for representing hexadecimal digits, the most common being: Hex EF, EF₁₆, EFh, 0xEF.

Commands 1–9 perform different actions depending on the projector status:

Status	Command	Action
Standby	0	switches the unit on and selects the last input memorized prior to switch off
	1–6	switch the unit on and select corresponding input
	7–9	switch the unit on and select the last input memorized prior to switch off
On	0	displays the Input Selection window of the OSD
	1–6	when OSD is not displayed, select corresponding inputs

The response of the unit to a Remote Control Key Code depends on the projector status:

Status	Response	Description
Standby	06 3A 06	Command acknowledged (may be valid or invalid)
On	06	Valid command (acknowledged and validated)
	15 ..	Invalid command (acknowledged but not validated)

where bytes marked with .. are not relevant.

2.2 Operation Commands

The following codes provide direct access to SIM2 C3X LUMIS User Interface operations not accessible via a single Remote Control command.

When an Operation Command is sent, OSD does not appear over the picture.

Most of the following commands require a valid signal on the selected input, therefore, if the status of the input signal is 'No signal' (see Section 2.3), they won't be executed and an Error response will be sent back by the projector.

Only the following commands are valid in a 'No signal' condition:

- Lamp Power
- Variable Iris

When a command is acknowledged, a response is sent back to the control system.

If the command is valid, the response (labeled 'OK' in the tables below) is either

20 XX YY

where bytes XX YY contain the new value of the parameter modified by the command, or

06.

If the command is invalid, the response (labeled 'Error' in the tables below) is

15 ..

where the byte marked with .. is not relevant.

On

The following commands switch the unit On and select the desired input at the same time. Selection of the Last Input (the one that was selected at the moment of the last switch off) is also possible.

Action	Command
On and Selection of Last Input	BE EF 02 06 00 6B E6 52 01 00 00 00 00
On and Selection of Input 1	BE EF 02 06 00 80 E5 49 01 00 00 00 00
On and Selection of Input 2	BE EF 02 06 00 B3 E5 4A 01 00 00 00 00
On and Selection of Input 3	BE EF 02 06 00 62 E4 4B 01 00 00 00 00
On and Selection of Input 4	BE EF 02 06 00 D5 E5 4C 01 00 00 00 00
On and Selection of Input 5	BE EF 02 06 00 04 E4 4D 01 00 00 00 00
On and Selection of Input 6	BE EF 02 06 00 37 E4 4E 01 00 00 00 00

If the command is acknowledged, the response is:

06 3A 06

where bytes marked with .. are not relevant.

Unfortunately, it is not possible to distinguish a valid command from an invalid one, as the response is the same in both cases.

Off

Action	Command	Response
Off	BE EF 02 06 00 51 E4 48 01 00 00 00 00	OK 06 Error 15 ..

Brightness

Action	Command	Response
Increment	BE EF 1A 0C 00 5E A3 00 00 02 00 00 00 00 00 00 00	OK 20 XX 00
Decrement	BE EF 1A 0C 00 9B F2 00 00 03 00 00 00 00 00 00 00	Error 15 ..
Get	BE EF 1A 0C 00 51 53 00 00 01 00 00 00 00 00 00 00	

In the response, XX is the hex representation of the value of Brightness.

Example: if the returned value is XX = 3C then Brightness value is 60.

Contrast

Action	Command	Response
Increment	BE EF 1A 0C 00 9D 5E 01 00 02 00 00 00 00 00 00 00	OK 20 XX 00
Decrement	BE EF 1A 0C 00 58 0F 01 00 03 00 00 00 00 00 00 00	Error 15 ..
Get	BE EF 1A 0C 00 92 AE 01 00 01 00 00 00 00 00 00 00	

In the response, XX is the hex representation of the value of Contrast.

Example: if the returned value is XX = 3C then Contrast value is 60.

Color

Action	Command	Response
Increment	BE EF 1A 0C 00 5A A7 03 00 02 00 00 00 00 00 00 00 00	OK 20 XX 00
Decrement	BE EF 1A 0C 00 9F F6 03 00 03 00 00 00 00 00 00 00 00	Error 15 ..
Get	BE EF 1A 0C 00 55 57 03 00 01 00 00 00 00 00 00 00 00	

In the response, XX is the hex representation of the value of Color.

Example: if the returned value is XX = 3C then Color value is 60.

Tint

Action	Command	Response
Increment	BE EF 1A 0C 00 99 5A 02 00 02 00 00 00 00 00 00 00 00	OK 20 XX 00
Decrement	BE EF 1A 0C 00 5C 0B 02 00 03 00 00 00 00 00 00 00 00	Error 15 ..
Get	BE EF 1A 0C 00 96 AA 02 00 01 00 00 00 00 00 00 00 00	

In the response, XX is the hex representation of the value of Tint.

Example: if the returned value is XX = 3C then Tint value is 60.

Cinema Mode

Action	Command	Response
Set Off	BE EF 1A 0C 00 84 12 0C 00 00 00 00 00 00 00 00 00 00	OK 20 XX 00
Set Auto	BE EF 1A 0C 00 91 52 0C 00 00 00 03 00 00 00 00 00 00	03 Auto
Get	BE EF 1A 0C 00 41 43 0C 00 01 00 00 00 00 00 00 00 00	00 Off
		Error 15 ..

In the response, XX is the hex representation of the value of Cinema Mode.

Example: if the returned value is XX = 03 then Cinema Mode is set to Auto.

Aspect

Action	Command	Response
Set Normal	BE EF 02 06 00 2A F4 83 01 00 00 00 00	OK 06
Set Anamorphic	BE EF 02 06 00 9D F5 84 01 00 00 00 00	Error 15 ..
Set Letterbox	BE EF 02 06 00 4C F4 85 01 00 00 00 00	
Set Panoramic	BE EF 02 06 00 7F F4 86 01 00 00 00 00	
Set Subtitle	BE EF 02 06 00 62 F5 8B 01 00 00 00 00	
Set Pixel to Pixel	BE EF 02 06 00 AE F5 87 01 00 00 00 00	
Set User 1	BE EF 02 06 00 51 F5 88 01 00 00 00 00	
Set User 2	BE EF 02 06 00 80 F4 89 01 00 00 00 00	
Set User 3	BE EF 02 06 00 B3 F4 8A 01 00 00 00 00	

Color Management

Primaries

Action	Command	Response
Set Native	BE EF 1A 0C 00 68 FE 41 00 00 00 00 00 00 00 00 00 00	OK 20 XX 00
Set HDTV	BE EF 1A 0C 00 A4 3F 41 00 00 00 01 00 00 00 00 00 00	00 Native
Set EBU	BE EF 1A 0C 00 B1 7F 41 00 00 00 02 00 00 00 00 00 00	01 HDTV
Set SMPTE-C	BE EF 1A 0C 00 7D BE 41 00 00 00 03 00 00 00 00 00 00	02 EBU
Set Auto	BE EF 1A 0C 00 9B FF 41 00 00 00 04 00 00 00 00 00 00	03 SMPTE-C
Get	BE EF 1A 0C 00 AD AF 41 00 01 00 00 00 00 00 00 00 00	04 Auto
		Error 15 ..

In the response, XX is the hex representation of the value of the Primaries adjustment.
 Example: if the returned value is XX = 02 then Primaries are set to EBU.

White Point

Action	Command	Response
Set Standard	BE EF 1A 0C 00 B7 DE 39 00 00 00 0A 00 00 00 00 00 00	OK 20 XX 00
Set High	BE EF 1A 0C 00 C8 5E 39 00 00 00 00 00 00 00 00 00 00	0A Standard
Set Medium	BE EF 1A 0C 00 04 9F 39 00 00 00 01 00 00 00 00 00 00	00 High
Set Low	BE EF 1A 0C 00 11 DF 39 00 00 00 02 00 00 00 00 00 00	01 Medium
Set Native	BE EF 1A 0C 00 DD 1E 39 00 00 00 03 00 00 00 00 00 00	02 Low
Set D75	BE EF 1A 0C 00 44 DF 39 00 00 00 0E 00 00 00 00 00 00	03 Native
Set D65	BE EF 1A 0C 00 7B 1F 39 00 00 00 0B 00 00 00 00 00 00	0E D75
Set D50	BE EF 1A 0C 00 9D 5E 39 00 00 00 0C 00 00 00 00 00 00	0B D65
Set C	BE EF 1A 0C 00 51 9F 39 00 00 00 0D 00 00 00 00 00 00	0C D50
Set User	BE EF 1A 0C 00 3B 5F 39 00 00 00 04 00 00 00 00 00 00	0D C
Get	BE EF 1A 0C 00 0D 0F 39 00 01 00 00 00 00 00 00 00 00	04 User
		Error 15 ..

In the response, XX is the hex representation of the value of the White Point.
 Example: if the returned value is XX = 0B then the White Point is set to D65.

Gamma

Action	Command	Response
Set ST1	BE EF 1A 0C 00 F6 CA 36 00 00 00 06 00 00 00 00 00 00	OK 20 XX 00
Set EN1	BE EF 1A 0C 00 7A 4B 36 00 00 00 08 00 00 00 00 00 00	06 ST1
Set EN2	BE EF 1A 0C 00 B6 8A 36 00 00 00 09 00 00 00 00 00 00	08 EN1
Set EN3	BE EF 1A 0C 00 DC 4A 36 00 00 00 00 00 00 00 00 00 00	09 EN2
Set EN4	BE EF 1A 0C 00 10 8B 36 00 00 00 01 00 00 00 00 00 00	00 EN3
Set EN5	BE EF 1A 0C 00 2F 4B 36 00 00 00 04 00 00 00 00 00 00	01 EN4
Set GR1	BE EF 1A 0C 00 E3 8A 36 00 00 00 05 00 00 00 00 00 00	04 EN5
Set GR2	BE EF 1A 0C 00 3A 0B 36 00 00 00 07 00 00 00 00 00 00	05 GR1
Set User	BE EF 1A 0C 00 45 8B 36 00 00 00 0D 00 00 00 00 00 00	07 GR2
Get	BE EF 1A 0C 00 19 1B 36 00 01 00 00 00 00 00 00 00 00	0D User
		Error 15 ..

In the response, XX is the hex representation of the value of Gamma.
 Example: if the returned value is XX = 04 then Gamma is set to EN5.

Dynamic Black

Action	Command	Response
Set Off	BE EF 1A 0C 00 07 AF 3D 00 00 00 00 00 00 00 00 00 00	OK 20 XX 00
Set On	BE EF 1A 0C 00 CB 6E 3D 00 00 00 01 00 00 00 00 00 00 00	00 Off
Get	BE EF 1A 0C 00 C2 FE 3D 00 01 00 00 00 00 00 00 00 00 00	01 On
		Error 15 ..

XX is the hex representation of the value of Dynamic Black.

Example: if the returned value is XX = 01 then Dynamic Black value is On.

Overscan

Action	Command	Response
Increment	BE EF 1A 0C 00 91 52 04 00 02 00 00 00 00 00 00 00 00	OK 20 XX 00
Decrement	BE EF 1A 0C 00 54 03 04 00 03 00 00 00 00 00 00 00 00	Error 15 ..
Get	BE EF 1A 0C 00 9E A2 04 00 01 00 00 00 00 00 00 00 00 00	

XX is the hex representation of the value of Overscan.

Example: if the returned value is XX = 0A then Overscan value is 10.

Variable Iris

Action	Command	Response
Set 0	BE EF 1A 0C 00 8B 23 58 00 00 00 00 00 00 00 00 00 00	OK 20 XX 00
Set 10	BE EF 1A 0C 00 F4 A3 58 00 00 00 0A 00 00 00 00 00 00 00	Error 15 ..
Set 20	BE EF 1A 0C 00 74 23 58 00 00 00 14 00 00 00 00 00 00 00	
Set 30	BE EF 1A 0C 00 0B A3 58 00 00 00 1E 00 00 00 00 00 00 00	
Set 40	BE EF 1A 0C 00 35 20 58 00 00 00 28 00 00 00 00 00 00 00	
Set 50	BE EF 1A 0C 00 46 A1 58 00 00 00 32 00 00 00 00 00 00 00	
Set 60	BE EF 1A 0C 00 CA 20 58 00 00 00 3C 00 00 00 00 00 00 00	
Set 70	BE EF 1A 0C 00 91 A7 58 00 00 00 46 00 00 00 00 00 00 00	
Set 80	BE EF 1A 0C 00 B7 26 58 00 00 00 50 00 00 00 00 00 00 00	
Set 90	BE EF 1A 0C 00 C8 A6 58 00 00 00 5A 00 00 00 00 00 00 00	
Set 100	BE EF 1A 0C 00 50 24 58 00 00 00 64 00 00 00 00 00 00 00	
Get	BE EF 1A 0C 00 4E 72 58 00 01 00 00 00 00 00 00 00 00 00	

XX is the hex representation of the status of the Variable Iris.

Example: if the returned value is XX = 01 then the Variable Iris is Closed.

Lamp Power

Action	Command	Response
Set 230	BE EF 1A 0C 00 45 01 25 00 00 00 E6 00 00 00 00 00 00 00	OK 20 XX YY
Set 240	BE EF 1A 0C 00 63 80 25 00 00 00 F0 00 00 00 00 00 00 00	Error 15 ..
Set 250	BE EF 1A 0C 00 1C 00 25 00 00 00 FA 00 00 00 00 00 00 00	
Set 260	BE EF 1A 0C 00 14 9E 25 00 00 00 04 01 00 00 00 00 00 00	
Set 270	BE EF 1A 0C 00 6B 1E 25 00 00 00 0E 01 00 00 00 00 00 00	
Set 280	BE EF 1A 0C 00 4D 9F 25 00 00 00 18 01 00 00 00 00 00 00	
Get	BE EF 1A 0C 00 E2 DE 25 00 01 00 00 00 00 00 00 00 00 00 00	

In the response, YY XX is the hex representation of the value of Lamp Power.

Example: if the returned value is XX = 0104 then Lamp Power value is 260W.

Memories

Action	Command	Response
Memory 1 Recall	BE EF 02 06 00 A8 F2 A1 01 00 00 00 00	OK 06
Memory 2 Recall	BE EF 02 06 00 9B F2 A2 01 00 00 00 00	Error 15 ..
Memory 3 Recall	BE EF 02 06 00 4A F3 A3 01 00 00 00 00	
Memory 4 Recall	BE EF 02 06 00 FD F2 A4 01 00 00 00 00	
Memory 5 Recall	BE EF 02 06 00 2C F3 A5 01 00 00 00 00	
Memory 6 Recall	BE EF 02 06 00 1F F3 A6 01 00 00 00 00	

2.3 Status Commands

Status Commands may be used to get the current value of the main projector parameters. Sections below describe the responses when the unit is On. It is not possible to receive a significant response when the unit is in Standby state.

Status Commands

Parameter	Command
Projector Status	BE EF 10 0A 00 34 B7 01 01 00 01 01 15 01 00 00 02
Signal Status	BE EF 10 0A 00 33 37 01 01 00 01 01 15 01 00 00 08
Lamp Status	BE EF 10 0A 00 A9 36 01 01 00 01 01 15 01 00 01 10

Projector Status

If the unit is On, the returned packet (27 byte long) is described in the following table:

1E BE EF 10 13 00 01 01 00 01 01 15 01 00 00 02 00 00 00 SS
0 1 17 18 20 21

where bytes marked with .. are not relevant.

The response may be separated into 4 parts:

- 1 bytes (byte 0) that initiates the packet (1E)
- 17 bytes (bytes 1–17) that duplicate the sent command (apart from 2 of them — the CRC)
- 3 Error bytes (bytes 18–20) that signal errors in the processing of the command
- 1 Data byte (byte 21) that contains the requested data

If the 3 Error bytes (bytes 18–20) are 00 00 00 then requested data are valid. The table below explains the meaning of returned data.

- Byte 21 (labeled **SS** in the table above) contains **Projector Status**:

On	01
Lamp Ignition	02
Lamp Restrike	03
Lamp Cooling	04

Signal Status

When the unit is On, the returned packet (25 byte long) is described in the following table:

1E	BE	EF	10	11	00	01	01	00	01	01	15	01	00	00	08	00	00	00	SS	II
0	1																17	18		20	21			24

where bytes marked with .. are not relevant.

The response may be separated into 4 parts:

- 1 bytes (byte 0) that initiates the packet (1E)
- 17 bytes (bytes 1–17) that duplicate the sent command (apart from 2 of them — the CRC)
- 3 Error bytes (bytes 18–20) that signal errors in the processing of the command
- 2 Data bytes (bytes 21, 24) that contain the requested data

If the 3 Error bytes (bytes 18-20) are 00 00 00 then requested data are valid.

The tables below explain the meaning of returned data.

- Byte 21 (labeled **SS** in the table above) contains current **Input Status**:

OK	00
No Signal	01
Signal Out of Range	02

- Byte 24 (labeled **II** in the table above) contains **Current Input**:

1	Video	00
2	S-Video	02
3	YPrPb	04
	RGB	05
4	Graphics RGB	0C
	Graphics YPrPb	0D
5	HDMI 1	12
6	HDMI 2	13

Lamp Status

When the unit is On, the returned packet (27 byte long) is described in the following table:

1E	BE	EF	10	13	00	01	01	00	01	01	15	01	00	01	10	00	00	00	UU	UU	..	SS	LL	LL
0	1																17	18		20	21	22		24	25	26

where bytes marked with .. are not relevant.

The response may be separated into 4 parts:

- 1 bytes (byte 0) that initiates the packet (1E)

- 17 bytes (bytes 1–17) that duplicate the sent command (apart from 2 of them — the CRC)
- 3 Error bytes (bytes 18–20) that signal errors in the processing of the command
- 5 Data bytes (bytes 21–22, 24, 25–26) that contain the requested data

If the 3 Error Bytes (bytes 18–20) are 00 00 00 then requested data are valid.

The tables below explain the meaning of returned data.

- Bytes 21 and 22 (labeled **UU UU** in the table above) contain **Unit Working Hours**.
UU UU is the hex representation of the number of working hours.
Therefore, if, for instance, UU UU = 09 D8 then Unit Working Hours is 2520.

- Byte 24 (labeled **SS** in the table above) contains the **Lamp Status**:

Off	00
Ignition	01
On	02

- Bytes 25 and 26 (labeled **LL LL** in the table above) contain **Lamp Working Hours**.
LL LL is the hex representation of the number of working hours.
Therefore, if, for instance, LL LL = 01 B6 then Unit Working Hours is 438.

3 Examples

Send the simulated 'SWITCH ON FROM STANDBY' Remote Control keycode

Remote Control allows Switching on from Standby via the key '0'.
Send the code relative to key '0':

```
BE EF 02 06 00 6B E6 52 01 00 00 00 00
```

The projector switches on and the last source memorized prior to switch off is automatically selected.

Send the simulated 'MENU RIGHT' Remote Control keycode

Send the command:

```
BE EF 02 06 00 23 E7 5A 01 00 00 00 00
```

The On Screen Display appears on the screen.
The projector returns the response code:

```
06
```

which means that the command has been acknowledged with no error.

Send the 'CONTRAST DECREMENT' Operation Command

Contrast value is 60.
Send the command:

```
BE EF 1A 0C 00 58 0F 01 00 03 00 00 00 00 00 00 00
```

The projector returns the response code:

```
20 3B 00
```

which means:

- acknowledged with no error
- new Contrast value is now 3B = 59.

Send 'PROJECTOR STATUS' Status Command

Send the command:

```
BE EF 10 0A 00 34 B7 01 01 00 01 01 15 01 00 00 02
```

The projector returns the response code:

```
BE EF 10 13 00 .. .. 01 01 00 01 01 15 01 00 00 02 00 00 00 01 .. .. .. ..
```

which means:

- Command has been executed with success (Error bytes, 18-20, are 00 00 00)
- Projector is On (Projector Status, byte 21, is 01)

Please note that bytes marked with .. are not relevant.

THIS PAGE LEFT BLANK INTENTIONALLY

SIM2 Multimedia S.p.A.
Viale Lino Zanussi, 11 — 33170 Pordenone — Italy
Tel. +39.0434383256 — Fax +39.0434383260
www.sim2.com
info@sim2.it

SIM2 USA Inc.
10108 USA Today Way — Miramar, FL 33025 — USA
Tel. +1.954.4422999 — Fax +1.954.4422998
www.sim2usa.com
sales@sim2usa.com

SIM2 Deutschland GmbH
ArndStr. 34-36
60325 Frankfurt am Main — D
Tel. 0800.8007462, +49.1635007462
Fax 0800.9007462
www.sim2.de
info@sim2.de

SIM2 UK Ltd.
Steinway House, Worth Farm
Little Horsted, Nr. Uckfield, East Sussex
TN22 5TT — UK
Tel. +44.01825.750850 — Fax +44.01825.750851
www.sim2.co.uk
info@sim2.co.uk

SIM2 Asia Pacific Co. LTD
Room 905, Jing'an Tower
1701 Beijing Road West
Shanghai 200040 — China
Tel. +86-21-62881991
www.sim2.net.cn
vsheng@sim2.com